

Wireless Sensing, Actuation and Control -- with Applications to Civil Structures

Yang Wang¹, Jerome P. Lynch², Kincho H. Law¹

¹ Dept. of Civil and Environmental Engineering, Stanford Univ., Stanford, CA 94305, USA

² Dept. of Civil and Environmental Engineering and Dept. of Electrical Engineering and Computer Science, Univ. of Michigan, Ann Arbor, MI 48109, USA
wyanq98@stanford.edu, jerlynch@umich.edu, law@stanford.edu

Abstract. Structural monitoring and control have been subjects of interests in structural engineering for quite some time. Structural sensing and control technologies can benefit in terms of installation cost and time from wireless communication and embedded computing. The hardware and software requirements pose an interesting, interdisciplinary research challenge. This paper describes a low-cost wireless sensing system that is judiciously designed for large-scale applications in civil structures. Laboratory and field tests have been conducted to validate the performance of the prototype system for measuring vibration responses. By incorporating an actuation signal generation interface, the wireless sensing system has the capabilities to perform structural actuation and support structural control applications. Structural control tests have been performed to validate the wireless sensing and actuation system.

1 Introduction

Ensuring the safety of civil structures, including buildings, bridges, dams, tunnels, and others, is of utmost importance to society. Developments in many engineering fields, notably electrical engineering, mechanical engineering, material science, and information technology are now being explored and incorporated in today's structural engineering research and practice. For example, in the last couple of decades, structural sensors, such as micro-electro-mechanical system (MEMS) accelerometers, metal foil strain gages, fiber optic strain sensors, linear variable displacement transducers (LVDT), etc., have been employed to collect important information that could be used to infer the safety conditions or monitor the health of structures [1-3].

To limit the response of structures subjected to strong dynamic loads, such as earthquake or wind, structural control systems can be used. There are three basic types of structural control systems: passive, active and semi-active [4-6]. Passive control systems, e.g. base isolators, entail the use of passive energy dissipation devices to control the response of a structure without the use of sensors and controllers. Active control systems use a small number of large mass dampers or hydraulic actuators for the direct application of control forces. In a semi-active control system, semi-active

control devices are used for indirect application of control forces. Examples of semi-active structural actuators include active variable stiffness (AVS) systems, semi-active hydraulic dampers (SHD), electrorheological (ER) and magnetorheological (MR) dampers. Semi-active control is currently preferred by many researchers, because of its reliability, low power consumption, and adequate performance during large seismic events. In active or semi-active control systems, sensing devices are installed to record real-time structural response data for the calculation of control decisions.

In order to transfer real-time data in a structural monitoring or control system, coaxial cables are normally deployed as the primary communication link. However, cable installation is time consuming and can cost as much as \$5,000 US dollar per communication channel [7]. Large-scale structures, such as long-span cable-stayed bridges, could easily require over thousands of sensors and miles of cables [8]. To eradicate the high cost incurred in the use of cables, wireless systems could serve as a viable alternative [9]. Wireless communication standards, such as Bluetooth (IEEE 802.15.1), Zigbee (IEEE 802.15.4), Wi-Fi (IEEE 802.11b), etc. [10], are now mature and reliable technologies widely adopted in many industrial applications. Potential applications of wireless technologies in structural health monitoring have been explored by a number of researchers [11-19]. A comprehensive review of wireless sensors and their adoption in structural health monitoring can be found in reference [20].

As opposed to structural monitoring, where sensors are used in a passive manner to measure structural responses, researchers have now begun to incorporate actuation interface in wireless sensors for damage detection applications [21-23]. For example, actuation interfaces can be used to induce stress waves in structural elements by wireless "active" sensors. Corresponding strain responses to propagating stress waves can be used to infer the health of the component. An integrated actuation interface can also be used to potentially operate actuators for structural control [24-26].

Compared to traditional cable-based systems, wireless structural sensing and control systems have a unique set of advantages and technical challenges. Portable energy sources, such as batteries, are a convenient, albeit limited, supply of power for wireless sensing units. Nevertheless, the need for reliable and low-cost energy sources remains a key challenge for wireless sensors [27-29]. Furthermore, data transmission in a wireless network is inherently less reliable than that in cable-based systems, particularly when node-to-node communication ranges lengthen. The limited wireless bandwidth can also impede real-time data transmission as required by feedback structural control systems. Last but not least, the time delay issues due to transmission and sensor blockage need to be considered [25,26,30]. These issues need to be resolved with a system approach involving the selection of hardware technologies and the design of software/algorithmic strategies.

A "smart" sensor combines both hardware and software technologies to provide the capabilities that can acquire environmental data, process the measured data and make "intelligent" decisions [18]. The development of autonomous, self-sensing and actuating devices for structural monitoring and control applications poses an intriguing, interdisciplinary research challenge in structural and electrical engineering. The purpose of this paper is to describe the design and implementation of a modular system consisting of autonomous wireless sensor units for civil structures applications. De-

signed for structural monitoring applications, the wireless sensor consists of a sensing interface to which analog sensors can be attached, an embedded microcontroller for data processing, and a spread spectrum wireless radio for communication. Optionally, for field applications where signals subject to environmental effects and ambient vibrations are relatively noisy, a signal conditioning board is designed to interface with the wireless sensing unit for signal amplification and filtering. To support active sensing and control applications, a signal generation module is designed to interface with the wireless sensing unit. This wireless actuation unit combining sensing, data processing, and signal generation, can be used to issue desired actuation commands for real-time feedback structural control. Laboratory and field validation tests are presented to assess the performance of the wireless sensing and actuation unit for structural monitoring and structural control applications.

2 Hardware Design of Wireless Sensing and Actuation Units

The building block of a wireless monitoring system is the wireless sensing unit. Fig.1 shows the overall hardware of the wireless sensing unit, and the two optional off-board auxiliary modules for conditioning analog sensor outputs and actuation signal generation. This section first describes in detail the key characteristics and components of the wireless sensing unit design. Off-board modules for signal conditioning and actuation command generation are then presented.

2.1 Wireless Sensing Unit

A simple star-topology network, which is adopted for the prototype wireless sensing

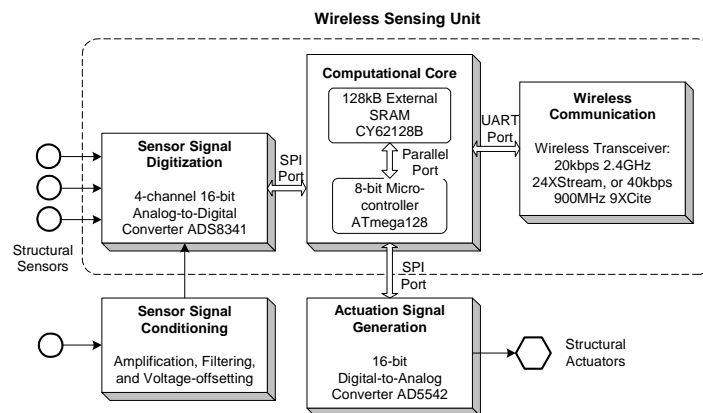

Fig. 1. Functional diagram detailing the hardware design of the wireless sensing unit. Additional off-board modules can be interfaced to the wireless sensing unit to condition sensor signals and issue actuation commands.

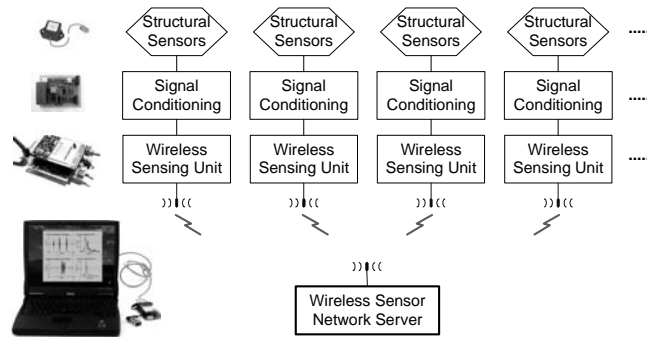

Fig. 2. An overview of the prototype wireless structural sensing system.

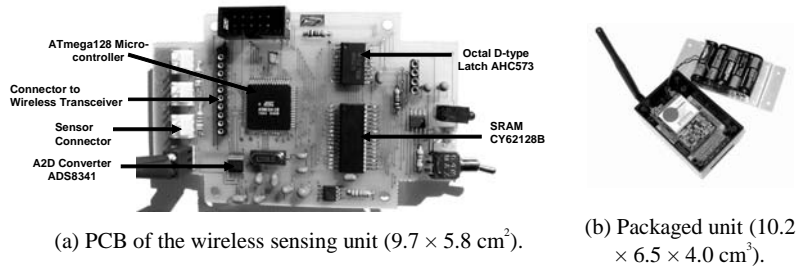

Fig. 3. Pictures of the wireless sensing unit.

system, includes a server and multiple wireless sensing units (Fig. 2). The functional diagram of the proposed wireless sensing unit is shown in the top part of Fig. 1. The wireless sensing unit consists of three functional modules: sensor signal digitization, computational core, and wireless communication. The sensing interface converts analog sensor signals into digital data which is then transferred to the computational core through a high-speed Serial Peripheral Interface (SPI) port. Besides a low-power 8-bit Atmel ATmega128 microcontroller, external Static Random Access Memory (SRAM) is integrated with the computational core to accommodate local data storage and analysis. The computational core communicates with a wireless transceiver through a Universal Asynchronous Receiver and Transmitter (UART) interface.

A simple two-layer printed circuit board (PCB) is designed and fabricated. As shown in Fig. 3, the PCB, wireless transceiver, and batteries are stored within an off-the-shelf weatherproof plastic container, which has a dimension of 10.2 by 6.5 by 4.0 cm³. Each sensing unit acts as an autonomous node capable of collecting, processing, and wirelessly transmitting data to other sensing units and the central server.

Sensing Signal Digitization Module

The main component of the sensor signal digitization module is a 4 channel 16 bit analog-to-digital (A/D) converter, Texas Instruments ADS8341. Each wireless sensing unit can accommodate signals from a heterogeneous set of up to 4 analog structural sensors (e.g. accelerometers, strain gages, among others). The 16 bit A/D resolution is sufficient for most applications in structural sensing. One requirement from the ADS8341 A/D converter is that the sensor signal should be between 0 and 5V. The highest sampling rate supported by this A/D converter is 100kHz, which is much higher than the sampling frequency typically needed for monitoring civil structures. This rate determines that each sampling consumes only 10 μ s. Therefore, the A/D conversion can be finished swiftly through the timer interrupt service of the microcontroller (ATmega128), without interrupting the execution of wireless communication or data processing programs.

Computational Core

The computational core of a wireless unit is responsible for executing embedded software instructions as required by the application end-user. A low-cost 8-bit microcontroller, Atmel ATmega128, is selected for this purpose. The key objective for this selection is to balance the power consumption and hardware cost versus the computation power needed by software applications. Running at 8MHz, the ATmega128 consumes about 15mA when it is active. Considering the energy capacity of normal batteries in the market, which is usually a few thousand milliamp-hours (mAh), normal AA batteries can easily support the ATmega128 active for hundreds of hours. Running in a duty cycle manner, with active and sleep modes interleaved, the ATmega128 microcontroller may sustain even longer before battery replacement is needed.

The ATmega128 microcontroller contains 128kB of reprogrammable flash memory for the storage of embedded software, which, based on our laboratory and field experiments, is sufficient to incorporate a wide variety of structural monitoring and control algorithms. One serial peripheral interface (SPI) and two universal asynchronous receiver and transmitter (UART) interfaces are provided by the ATmega128 to facilitate communication with other hardware components. The timer and interrupt modules of the ATmega128 are employed for executing routines that need to be precisely timed, e.g. sampling sensor data or applying actuation signal at specified frequencies.

The microcontroller also contains 4kB static random access memory (SRAM) for storing stack and heap variables, which as it turns out, is often insufficient for the execution of embedded data interrogation algorithms. To address this issue, an external 128kB memory chip, Cypress CY62128B, is incorporated within the wireless sensing unit design. Furthermore, hardware and software procedures are implemented to bypass the 64kB memory address space limitation of the ATmega128, to ensure that the full 128kB address space of the CY62128B can be utilized.

Wireless Communication Module

The wireless communication module provides the interface for the unit to exchange data with other wireless units, or a data server with a wireless transceiver attached. Sufficient communication reliability, range, and data transfer rate are needed to employ the wireless units in civil structures. On the other hand, due to stringent battery power constraints, the wireless module, which is the most power-consuming component of a typical wireless sensing unit, should not consume too much battery power while active. Certain trade-offs have to be achieved to delicately balance performance and low power requirements. Wireless frequency allocation regulated by the government is another factor that should be considered while selecting wireless transceivers.

The wireless sensing unit is designed to be operable with two different wireless transceivers: 900MHz MaxStream 9XCite and 2.4GHz MaxStream 24XStream. Pin-to-pin compatibility between these two wireless transceivers makes it possible for the two modules to share the same hardware connections in the wireless unit. Because of the different data rates, embedded software for using the two transceivers is slightly different. This dual-transceiver support affords the wireless sensing/actuation unit to have more flexibility in terms of not only geographical area, but also data transfer rate, communication range, and power consumption. Table 1 summarizes the key performance parameters of the two wireless transceivers. As shown from the table, the data transfer rate of the 9XCite is double that of the 24XStream, while 24XStream provides a longer communication range but consumes much more battery power. Both transceivers support peer-to-peer and broadcasting communication modes, rendering information flow in the wireless sensor network more flexible.

Table 1. Key performance parameters of the wireless transceivers.

Specification	9XCite	24XStream
Operating Frequency	ISM 902-928 MHz	ISM 2.4000 – 2.4835 GHz
Channel Mode	7 frequency hopping channels, or 25 single frequency channels	7 frequency hopping channels
Data Transfer Rate	38.4 kbps	19.2 kbps
Communication Range	Up to 300' (90m) indoor, 1000' (300m) at line-of-sight	Up to 600' (180m) indoor, 3 miles (5km) at line-of-sight
Supply Voltage	2.85VDC to 5.50VDC	5VDC ($\pm 0.25V$)
Power Consumption	55mA transmitting, 35mA receiving, 20 μ A standby	150mA transmitting, 80mA receiving, 26 μ A standby
Module Size	1.6" \times 2.825" \times 0.35" (4.06 \times 7.17 \times 0.89 cm ³)	1.6" \times 2.825" \times 0.35" (4.06 \times 7.17 \times 0.89 cm ³)
Network Topology	Peer-to-peer, broadcasting	Peer-to-peer, broadcasting

* For details about the transceivers, see <http://www.maxstream.net>.

2.2 Sensor Signal Conditioning Module

For field applications, a wireless monitoring system must be capable of recording both ambient and forced structural vibrations. With ambient vibrations typically defined by

small amplitudes, a high-resolution (16-bit or higher) A/D converter is normally needed by a structural monitoring system. The placement of the low-cost 16-bit ADS8341 A/D converter leaves the A/D vulnerable to electrical noise present in the circuit. From experimental tests, the effective resolution for the A/D channels is found to be approximately 13-bit, which is likely insufficient for sampling low-amplitude vibration data. Additionally, for the ADS8341 A/D converter, the sensor signals must be within 0 to 5V. A signal conditioning module is thus needed to amplify signals, filter out noise, and shift sensor signals within range.

Sensor signals are fed through the signal conditioning module prior to the A/D conversion, as shown in the lower left part of Fig. 1. As shown in Fig. 4(a), the filtering circuits consist of a high-pass resistor-capacitor (RC) filter with a cutoff frequency of 0.02Hz and a low-pass fourth-order Bessel filter with a cutoff frequency of 25Hz. The linear-phase shift property of the Bessel filter ensures a constant time delay for signals in the pass band, thus maintaining the signal waveform in the time domain. Fig. 4(b) shows the complete signal conditioning board that includes circuit modules that support the filtering, offsetting, and amplification functions.

To illustrate the performance of the signal conditioning module, Fig. 5 shows two acceleration time histories, where the signal outputs are fed into the A/D converter

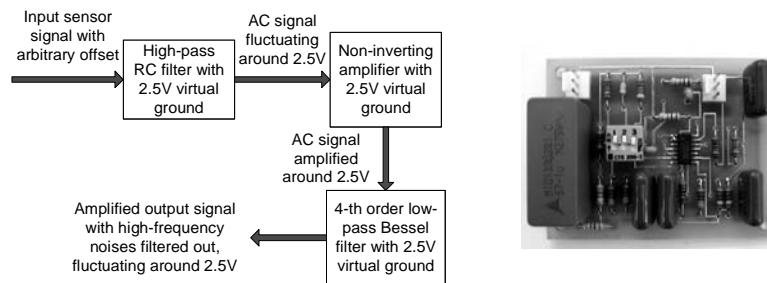

(a) Functional Diagram of the Circuits.

(b) PCB board ($5.0 \times 6.5 \text{ cm}^2$).

Fig. 4. Sensor signal conditioning module.

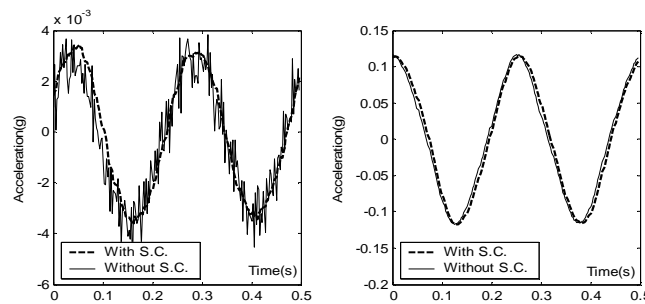

(a) Low vibration amplitude.

(b) High vibration amplitude.

Fig. 5. Wireless accelerometer data with and without signal conditioning.

with and without the signal conditioning (S.C.) module. As shown in Fig. 5(a), when the vibration amplitude is low, in which case the Signal-to-Noise-Ratio (SNR) is low, the sensor data with signal conditioning becomes much smoother than the data without signal conditioning. When the vibration amplitude is higher, i.e. when the SNR is high, the difference between the data collected with and without signal conditioning is almost negligible with respect to the signal amplitude, as shown in Fig. 5(b).

2.3 Actuation Signal Generation Module

The functionality of the wireless sensing unit can be extended to support structural actuation and control applications. The key component of the actuation signal generation module is the Analog Device AD5542 digital-to-analog (D/A) converter which converts unsigned 16-bit integer numbers issued by the microcontroller into a zero-order hold analog output spanning from -5 to 5V. It should be noted that the wireless sensor is based upon 5V electronics; this requires an auxiliary -5V power supply to be included in the actuation signal generation module. The switching regulator, Texas Instruments PT5022, is employed to convert the 5V voltage source from the wireless sensing unit into a regulated -5V signal. Another component included in the actuation signal generation module is an operational amplifier (National Semiconductor LMC6484), to shift the output signal to have a mean of 0V. The actuation signal generation module is capable of outputting -5 to 5V analog signals within a few microseconds after the module receives the digital command from the microcontroller.

The actuation signal generation module is connected with the wireless sensing unit through two multi-line cables: an analog signal cable and a digital signal cable. The digital signal cable connects between the D/A converter of the signal generation module to the microcontroller of the wireless sensing unit via the SPI interface. The analog cable is used to transfer an accurate +5V voltage reference, from the wireless sensing unit to the actuation board. The generated actuation signal is transmitted to the structural actuator through a third output cable in the module. Fig. 6 shows the signal conditioning module, which is designed as a separate board readily interfaced with the wireless sensing unit for actuation and control applications.

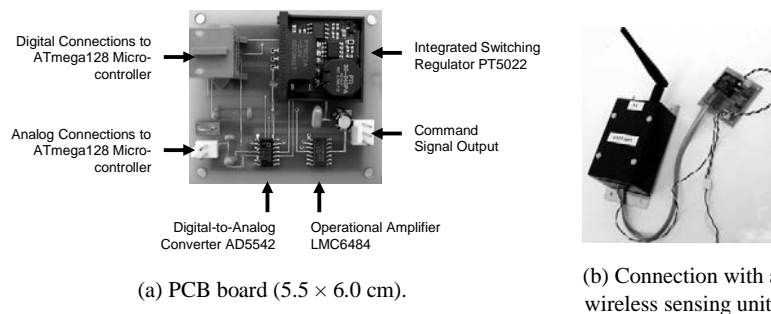

Fig. 6. Pictures of the control signal module.

3 Wireless Sensing for Structural Testing and Monitoring

The wireless sensing unit prototypes (with and without the auxiliary modules), have undergone a number of large-scale validation tests to assess performance and verify the prototype design and implementation [31-33]. Field validation tests are particularly important, since they subject the wireless units under the complexities of real structural environments. For example, the long range communication of the wireless sensors is quantified. Furthermore, structural obstructions can pose significant challenges for propagation of wireless communication signals. Last but not least, for typical field tests, ambient responses from normal daily operations give very low signal amplitude, which could be difficult to measure with high precision. This section describes two validation results; first is a large shake table test conducted at the National Center for Research on Earthquake Engineering (NCREE) in Taipei, Taiwan, and the second is a field test conducted at Geumdang Bridge, Icheon, South Korea.

3.1 Laboratory Tests on a 3-Story Steel Frame at NCREE, Taiwan

In collaboration with researchers at NCREE, Taiwan, the wireless monitoring system is installed within a three-story steel frame structure mounted on a shake table. As shown in Fig. 7(a) and (b), the three-story single-bay steel frame structure has a 3 by 2m² floor area and a 3m inter-story height. H150x150 x7x10 I-section elements are used for all columns and beams with each beam-column joint designed as bolted connections. Each floor is loaded with concrete blocks and has a total mass of 6,000kg. The test structure is mounted on a 5 by 5m² shake table capable of applying base motion in 6 independent degrees-of-freedom.

As presented in Fig. 7(a), the test structure is instrumented with a wireless monitoring system consisting of 6 wireless sensing units. Because of local frequency band requirements, the MaxStream 24XStream wireless transceiver operating at 2.4GHz spectrum is employed for the wireless sensing unit. The instrumentation strategy of the wireless monitoring system is governed by an interest in both the acceleration response of the structure as well as the strain behavior at the base column. As shown in Fig. 7(a), one wireless sensing unit is responsible for the three accelerometers instrumented on a floor. For example, wireless sensing unit WSU6 is used to record the acceleration of the structure at locations A1, A2 and A3. This configuration of accelerometers is intended to capture both the longitudinal and lateral response of each floor, as well as any torsion behavior.

The accelerometers employed with the wireless sensing units are the Crossbow CXL01 and CXL02 (MEMS) accelerometers, which have acceleration ranges of $\pm 1g$ and $\pm 2g$, respectively. The CXL01 accelerometer has a noise floor of 0.5mg and a sensitivity of 2V/g, while the CXL02 accelerometer has a noise floor of 1mg and a sensitivity of 1V/g. Additionally, 4 metal foil strain gages with nominal resistances of 120 Ω and a gage factor of 2, are mounted on the base column to measure the column flexural response during base excitation. To record the strain response, a Wheatstone

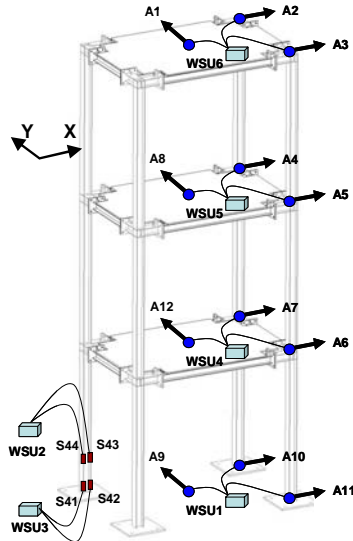

(a) Instrumentation strategy.

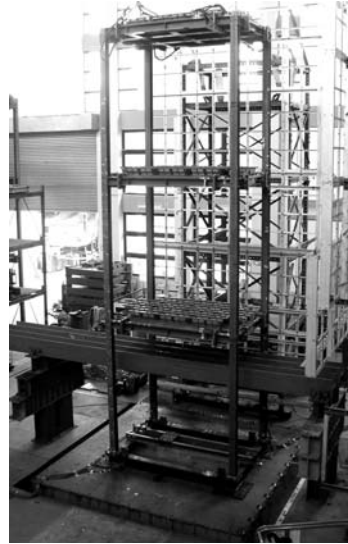

(b) Shake table setup.

Fig. 7. Three-story steel benchmark structure.

bridge amplification circuit is used to convert the changes in gage resistance into voltage signals. Two wireless sensing units (WSU2 and WSU3) are dedicated to recording the strain response with each unit connecting to two gages. As for comparison, Setra141-A accelerometers (with acceleration range of $\pm 4g$ and a noise floor of $0.4mg$) and 120• metal foil strain gages connecting to a traditional cable-based data acquisition system are installed side-by-side.

Various ambient white noise and seismic excitations, including El Centro (1940), Kobe (1995), and Chi-Chi (1999) earthquake records, were applied to excite the test structure [33]. The results shown in Fig. 8 are based on a 90 sec bi-directional white noise excitation of 1m/s and 0.5m/s standard deviation velocities in the X and Y directions respectively. The time history responses for both acceleration and strain measurements recorded (at locations A1, A2, and S44) by the wireless monitoring system are identical to those measured independently by the cable-based monitoring system.

To illustrate the utilization of the on-board microcontroller for data interrogation, an auto-regressive (AR) time series model which is often used for damage detection applications [34] is implemented. During the test, the wireless sensing units determine the optimal AR model fit to the acceleration and strain data. Once the AR model is calculated, the model coefficients are then transmitted to the central server. As shown in Fig. 8(b), the acceleration time history responses reconstructed using 20 AR model coefficients are compared with the directly recorded raw time history data at sensor locations A6 and A9 (located on the first floor and table, respectively). The reconstructed time history using the AR model coefficients can accurately predict the re-

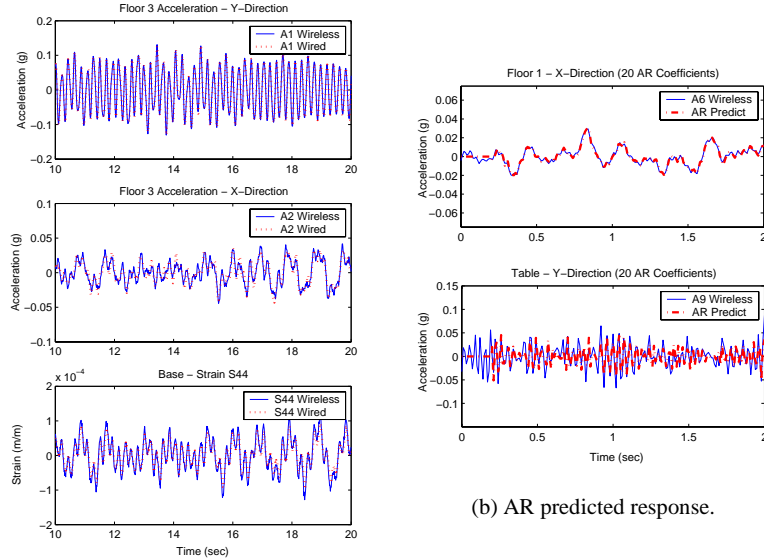

(a) Acceleration and strain time histories.

Fig. 8. White noise ground excitation tests at NCREE.

sponse of the structure. That is, with the microcontroller, useful computations can be performed on the wireless sensing unit, and the amount of data (in this case, the AR coefficients) that need to be transmitted in real time can be significantly reduced.

3.2 Field Validation Tests at the Geumdang Bridge, South Korea

In collaboration with researchers at the Korea Advanced Institute of Science and Technology (KAIST), a field validation test has been conducted on the Geumdang Bridge in Icheon, South Korea. Designed and managed by the Korea Highway Corporation (KHC), the two-lane test road is heavily instrumented to measure the performance of the pavement systems [35]. One convenient feature of this testing venue is that KHC has the ability to open or close the test road at will and to reroute traffic.

The Geumdang Bridge has a total span of 273m, and is designed using two different section types. The northern portion is constructed with four independent spans (with span lengths of 31, 40, 40 and 40m respectively), each of which is designed using a 27cm concrete deck supported by four pre-cast concrete girders. The validation test is performed on the southern portion of the Geumdang Bridge. As shown in Fig. 9, the southern portion of the bridge is constructed with a continuous 122m long post-tensioned box girder. The depth of the box girder is 2.6m, and the width at the bridge deck is about 12.6m. The southern portion is subdivided into three sections (38, 46 and 38m respectively) which are supported by the abutment and the three piers.

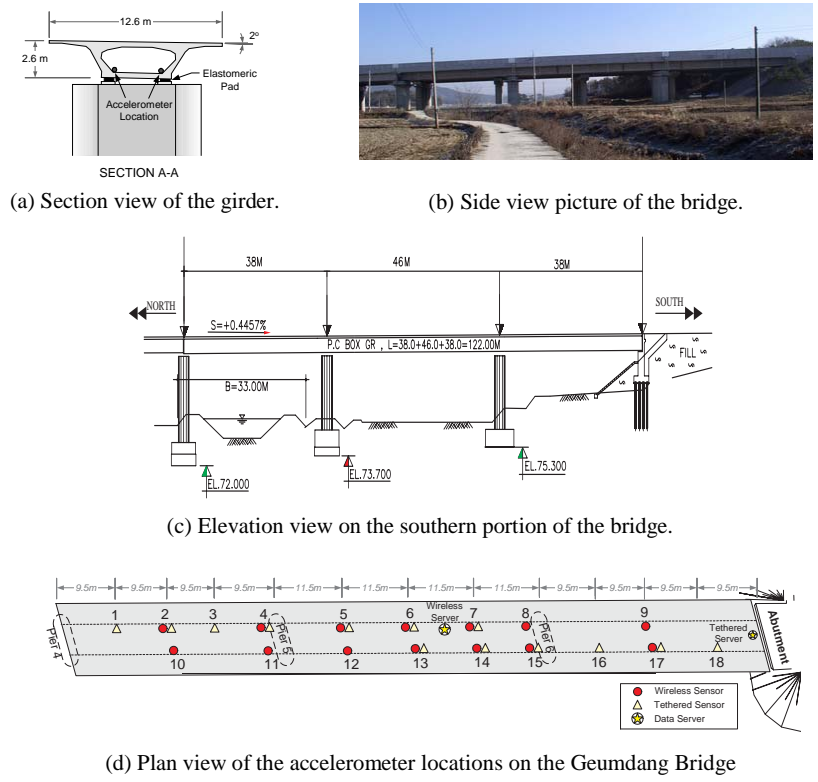

Fig. 9. Illustration of the Geumdang Bridge and wireless sensor deployment.

Table 2. Parameters for accelerometers used in the cabled and wireless sensing systems.

	PCB393 (Cabled System)	PCB3801 (Wireless System)
Sensor Type	Piezoelectric	Capacitive
Maximum Range	± 0.5 g	± 3 g
Sensitivity	10 V/g	0.7 V/g
Bandwidth	2000 Hz	80 Hz
RMS Resolution (Noise Floor)	50 μ g	500 μ g
Minimal Excitation Voltage	18 VDC	5 VDC

As shown in Fig. 9(d), a total of 14 accelerometers are deployed for the wireless system. Furthermore, 13 cabled accelerometers are also instrumented with the tethered monitoring system. The accelerometers and their characteristics for the two systems are tabulated in Table 2. The accelerometers used in the cabled system are PCB piezo-

electric accelerometers Piezotronics 393B12, which has a very low noise floor of only $50\mu\text{g}$, and a high sensitivity of 10V/g and is well suited for use in ambient vibration applications, because of its low noise to signal level. Additionally, the cabled system employs a 16 channel PCB Piezotronics 481A03 signal conditioner which can simultaneously amplify (up to a gain of 200) and filter the sensor signal before digitization. A National Instruments 12-bit data acquisition card, NI DAQCard-6062E, is used to sample and collect the conditioned signal.

For the wireless system, an inexpensive PCB Piezotronics 3801D1FB3G MEMS accelerometer is selected. Operating at 5 VDC, this capacitive accelerometer can be conveniently powered by the wireless sensing unit. The noise floor of the PCB3801 accelerometers is $500\mu\text{g}$, which is ten times that of the PCB383 accelerometers used in the cabled system. Meanwhile, the sensitivity of the PCB3801 is lower than the PCB383. Therefore, with a lower Signal-to-Noise-Ratio (SNR) ratio, signals from the PCB3801 are expected to be noisier than those from the PCB383. The wireless sensing units are installed with MaxStream 9XCite radios operating on the 900MHz frequency spectrum. To improve the SNR ratio, the optional signal conditioning module as described in section 2.2 is employed for the wireless sensing unit. A laptop connected with a MaxStream 9XCite transceiver, located at around the middle of the bridge, is employed to collect sensor data from all the 14 wireless sensing units.

Vibration tests are conducted by driving a 40-ton truck at set speeds to induce structural vibrations into the system. For all the tests conducted, no data losses have been observed and the wireless sensing system proves to be highly reliable using the designed communication protocol for synchronized and continuous data acquisition. Fig. 10(a) shows the acceleration data recorded with a sampling rate of 200Hz at sensor location #17 when the truck was crossing the bridge at 60km/h. Despite the difference in the accelerometer and signal conditioning devices, the recorded output by the wireless system has the precision identical to that offered by a commercial cabled system. With the microcontroller, an embedded 4096 point FFT algorithm is used to determine the Fourier transform to the acceleration data. As shown in Fig. 10(b), the first three dominant frequencies can easily be identified as 3.0, 4.3 and 5Hz, which are very close to the bridge natural frequencies previously published [35].

Once the dominant frequencies are determined, the complex numbers of the Fourier transform in the interested frequency range are wirelessly transmitted to the central server, so that the operational deflection shapes (ODS) of the bridge under the truck loading can be computed. Fig. 10(c) illustrates the ODS for the first three dominant frequencies computed from the wireless sensor data. The ODS shapes are not the bridge mode shapes, since the external excitation by driving the truck along the bridge is difficult to accurately quantify. Nevertheless, the ODS shapes are dominated by the corresponding modes and are typically good approximations to the mode shapes.

4 Wireless Sensing and Control

Supplemented by the actuation signal generation module described in Section 2.3, the functionality of the wireless sensing unit can be extended to command structural ac-

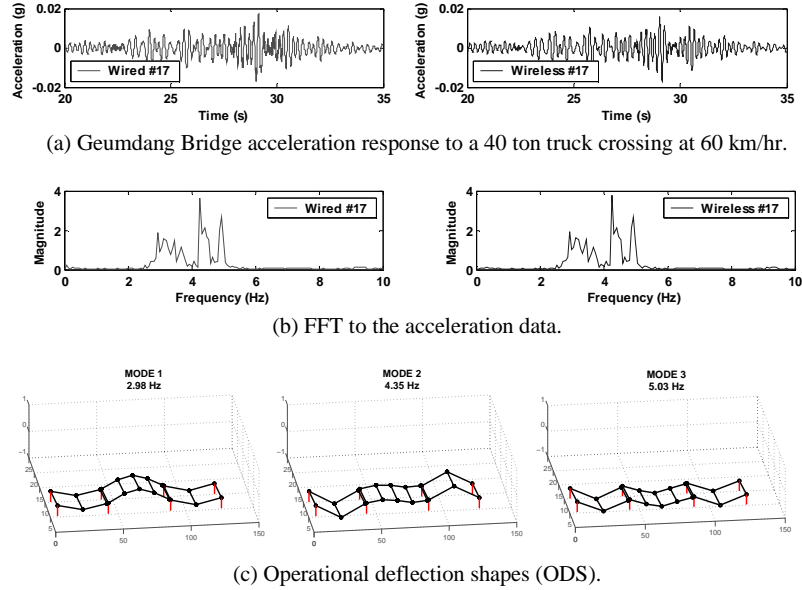

Fig. 10. Geumdang Bridge forced vibration data and frequency-domain analysis.

tors for structural control applications. With a wireless sensor network capable of exchanging real-time sensor data among the sensing units, feedback control decisions can be determined in real time to limit structural responses. The current prototype implementation focuses on the use of a wireless system for semi-active control using MR dampers as control actuators. Fig. 11 illustrates the operations of a wireless structural sensing and control system, termed herein as WiSSCon.

As shown in the figure, the system consists of multiple wireless sensing and actuation units. The wireless sensing units (S_1 , S_2 , and S_3) collect structural response data. At each time step, the wireless control unit (C_1), which consists of a wireless sensing unit and an actuation signal generation module, broadcasts a beacon signal to all the sensing units via the wireless communication channel. Upon receiving the beacon signal, the sensing units immediately send the sensor data to the control unit. The control unit processes the sensor data with the embedded microcontroller, and computes the control signals to be sent to actuate the MR damper.

To validate the concept of the WiSSCon system, experimental tests were conducted at NCREE, Taiwan, using the same three-story steel frame described in section 3.1. In the feedback control experiments, the test structure is implemented with accelerometers, velocity transducers, and LVDTs at all floors. Both accelerometers and velocity transducers are connected to the wireless sensing units. A cabled data acquisition system is used to collect the test data from the sensors for later analysis. Furthermore, a cabled control system is also available and is used to serve as the baseline reference system to which the WiSSCon system can be compared.

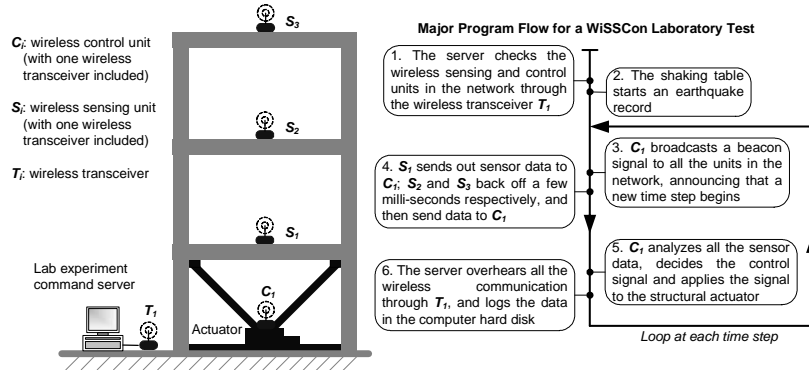
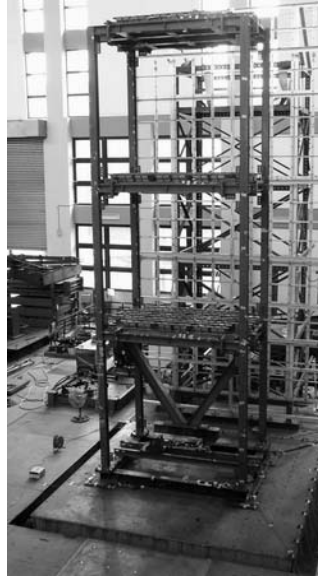

Fig. 11. Example illustration of the WiSSCon system instrumented on a 3-story test structure with one actuator.

The laboratory setup for the structural control experiment is shown in Fig. 12. An MR damper with a maximum force capacity of 20kN and a piston stroke of $\pm 0.054\text{m}$ is installed at the base floor. During a dynamic test, the damping coefficient of the MR damper can be changed in real time by issuing an analog command signal between 0 to 1V. This command signal controls the electric current of the electromagnetic coil in the MR damper, which in turn, generates the magnetic field that sets the viscous damping properties of the MR fluid inside the damper. The damper hysteresis behavior is determined using a modified Bouc-Wen model [36]. During dynamic excitation, the control unit, either cabled or wireless, has to maintain the time history of the damper model so that the damper hysteresis is known at all times and a suitable voltage can be determined for the MR damper.

In this structural control experiment, a discrete Linear Quadratic Regulator (LQR) control algorithm is employed to compute control forces applied by the MR damper. Detailed descriptions of the discrete LQR algorithm can be found in many control textbooks [37]. In essence, weighting matrices are selected for a scalar cost function that considers the state response of the structure and the energy required by the system actuators. The LQR algorithm determines a constant feedback “gain” matrix, which is used to optimally compute the desired control force based on the sensor output measurements. Prior to the dynamic tests, the constant “gain” matrix can be embedded into the microcontroller of the wireless control unit for real-time execution. Specifically, the experimental study is designed to execute velocity feedback control in real time. Each wireless sensing or control unit collects the floor velocity using a Tokyo Sokushin VSE15-D velocity meter, which has a measurement range of $\pm 1\text{m/s}$, sensitivity of 10V/(m/s) and a dynamic frequency range of 0.1 to 70Hz. The transducer is well suited for the test structure whose primary modal frequencies fall well below 10Hz.

Time delay is an important issue in real-time feedback control. There are three major components that constitute the time delay: sensor data acquisition, control decision calculation, and actuator latency in applying the desired control force. Normally, the



(a) Shake table setup.

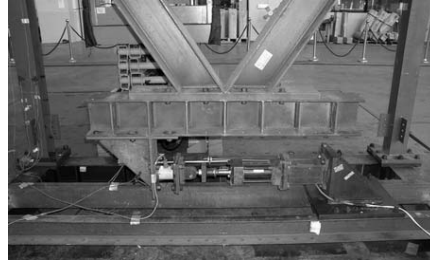

(b) The MR damper and its supporting brace.

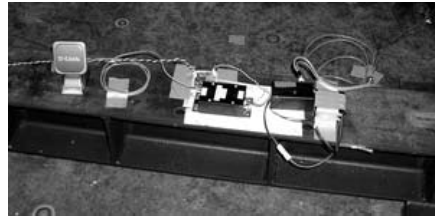

(c) The wireless control unit.

Fig. 12. Wireless structural sensing and control test with one MR damper installed between the 1st floor and the base floor of the structure.

control decision calculation time is the minimum among the three, while the actuator latency being the maximum. In the LQR formulation, time delay from sensor data collection to control force application is assumed to be zero, even though a non-zero time delay always exists in practice. In active structural control, time delay may cause system instability, in which the control force could actually excite the structure. In semi-active control, the actuators normally dissipate vibration energy, without the capability to excite the structure. Nevertheless, large time delay remains an important issue in semi-active control, since it can degrade the performance of the system.

The difference between a wired control system and a wireless control system is mostly in the sensor data acquisition time. For the cabled control system, it is estimated that the time delay due to data acquisition is approximately 5ms. For the Max-Stream 24XStream wireless transceivers, a single wireless transmission time delay is about 20ms. For this experimental study, at each time step, four wireless transmissions are performed: a beacon signal sent by the control unit and 3 data packets transmitted one at a time by the three wireless sensors. Therefore, the WiSSCon system implemented upon the 24XStream wireless transceiver provides a control time step of about 80ms resulting in an achievable sampling frequency of 12.5Hz. Besides validating the concept of feedback wireless structural sensing and control, the experimental study attempts to investigate the influence of this time delay difference.

Fig. 13 shows the maximum absolute inter-story drift of each floor obtained from the tests conducted using the El Centro earthquake record with its peak acceleration

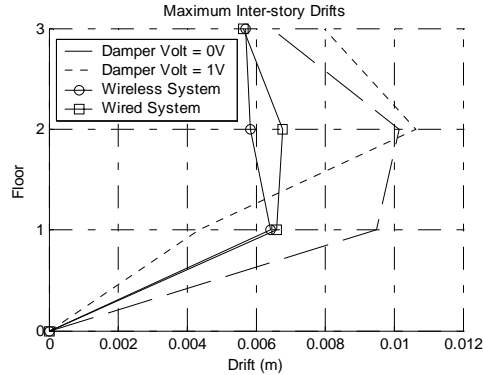

Fig. 13. Maximum inter-story drifts for tests with a scaled El Centro record as ground excitation.

scaled to 1m/s^2 . Detailed description of the structural control tests can be found in reference [26]. As for comparison, two passive control tests when the MR damper voltage is fixed at 0 and 1V respectively, are also shown in the figure. The results illustrate that the LQR control with the cabled and wireless systems give more uniform maximum inter-story drifts for all three floors than the passive control tests. These preliminary results also show the wireless control system, even though with significantly larger time delay, suffers only minor performance degradation. Current investigation to improve wireless communication and minimize time delay is underway.

5 Summary and Discussion

Smart sensing devices must include capabilities that can interface with sensors, process acquired data and make decisions for a particular application of interest. Research in this area requires all facets of hardware technologies and software strategies to be selected, designed and implemented for the application. This paper describes the basic modules that compose a wireless sensing device. Building upon off-the-self components, the prototype wireless sensing unit described in this paper is capable of monitoring civil structures subjected to ambient and forced vibrations. The cost of wireless monitoring systems, including labor as well as installation efforts, is significantly lower than that of tethered systems that require installation of extensive lengths of coaxial cables. In addition, the performance features of a wireless sensing system differ greatly from the tethered counterparts. Wireless systems are highly decentralized with A/D conversion and data processing performed locally at the wireless sensing units, as opposed to at the central server. Embedded computations allow parallel processing of measurement data and lower energy consumption. Structural monitoring algorithms can be implemented on the sensor units for data processing and decision making. However, precise synchronization of raw time history data in a large scale wireless monitoring system remains a challenging task.

By including an actuation signal generation module in the wireless sensing unit, the potential application of a WiSSCon system for feedback structural control has been illustrated. The WiSSCon system could not only lead to significant reduction in system cost by eradicating cables in the control system but also, by using low cost micro-controllers, provide a highly flexible and adaptable system configuration because of wireless communication. With the embedded microcontroller, sophisticated “intelligent” computational strategies can also be incorporated [38,39]. For real-time feedback applications, the adverse effects of communication and computation time delay using the WiSSCon system could be mitigated by using algorithms that can specifically address the time delay issue. One possibility is to explore decentralized (or partially decentralized) structural control algorithms [40,41] that optimal control decisions are made using measurement output data from its own sensor or from only their neighboring units. Feasibility study and laboratory investigation of wireless decentralized controls are currently underway [42]. Further research includes investigation of “intelligent” strategies that can be implemented in the WiSSCon system for civil structure monitoring and control applications.

Acknowledgement

This research is partially funded by the National Science Foundation under grants CMS-9988909 (Stanford University) and CMS-0421180 (University of Michigan), and the Office of Naval Research Young Investigator Program awarded to Prof. Lynch at University of Michigan. The first author is supported by an Office of Technology Licensing Stanford Graduate Fellowship. Additional support was provided by the Rackham Grant and Fellowship Program at the University of Michigan. Prof. Chin-Hsiung Loh, Dr. Pei-Yang Lin, and Mr. Kung-Chun Lu at National Taiwan University provided generous support for conducting the shake table experiments at NCREE, Taiwan. The authors would also like to express their gratitude to Professors Chung Bang Yun and Jin Hak Yi, as well as Mr. Chang Geun Lee, from the Korea Advanced Institute of Science and Technology (KAIST), for the access to Geumdang Bridge. During this study, the authors have received many valuable advices on the PCB layout from Prof. Ed Carryer at Stanford University. The authors appreciate the generous assistance from the individuals acknowledged above.

References

1. Chang, P.C., Flatau, A., Liu, S.C.: Review Paper: Health Monitoring of Civil Infrastructure. *Struct. Health Monit.* 2 (2003) 257-267
2. Farrar, C.R., Sohn, H., Hemez, F.M., Anderson, M.C., Bement, M.T., Cornwell, P.J., Doebling, S.W., Schultze, J.F., Lieven, N., Robertson, A.N.: Damage Prognosis: Current Status and Future Needs. Report LA-14051-MS, Los Alamos National Laboratory, NM (2003)
3. Elgamal, A., Conte, J.P., Masri, S., Fraser, M., Fountain, T., Gupta, A., Trivedi, M., El Zarki, M.: Health Monitoring Framework for Bridges and Civil Infrastructure. Proc. of the 4th Int. Workshop on Structural Health Monitoring, ed. F.-K. Chang. Stanford, CA (2003) 123-130

4. Yao, J.T.: Concept of Structural Control. *ASCE J. of Struct. Div.*. 98 (1972) 1567-1574
5. Soong, T.T., Spencer, B.F.: Supplemental Energy Dissipation: State-of-the-art and State-of-the-practice. *Engng. Struct.* 24 (2002) 243-259
6. Chu, S.Y., Soong, T.T., Reinhorn, A.M.: Active, Hybrid, and Semi-active Structural Control: a Design and Implementation Handbook. John Wiley & Sons, NJ (2005)
7. Celebi, M., Seismic Instrumentation of Buildings (with Emphasis on Federal Buildings). Report No. 0-7460-68170 United States Geological Survey (USGS). Menlo Park, CA (2002)
8. Solomon, I., Cunnane, J., Stevenson, P.: Large-scale Structural Monitoring Systems. Proc. of SPIE Nondestructive Evaluation of Highways, Utilities, and Pipelines IV. SPIE Vol. 3995, ed. A.E. Aktan, S.R. Gosselin (2000) 276-287
9. Straser, E.G., Kiremidjian, A.S.: A Modular, Wireless Damage Monitoring System for Structures. Report No. 128, John A. Blume Earthquake Eng. Ctr., Stanford Univ., (1998)
10. Cooklev, T.: IEEE Wireless Communication Standards: A Study of 802.11, 802.15, and 802.16. IEEE Press, NY (2004)
11. Kling, R.M.: Intel Mote: an Enhanced Sensor Network Node. Proc. of Int. Workshop on Advanced Sensors, Struct. Health Monitoring, and Smart Struct.. Keio Univ., Japan (2003)
12. Lynch, J.P., Sundararajan, A., Law, K.H., Kiremidjian, A.S., Kenny, T., Carryer, E.: Embedment of Structural Monitoring Algorithms in a Wireless Sensing Unit. *Struct. Eng. Mech.* 15 (2003) 285-297
13. Arms, S.W., Townsend, C.P., Galbreath, J.H., Newhard, A.T.: Wireless Strain Sensing Networks. Proc. of 2nd Euro. Work. on Struct. Health Monitoring. Munich, Germany (2004)
14. Glaser, S.D.: Some Real-world Applications of Wireless Sensor Nodes. Proc. of SPIE 11th Annual Inter. Symp. on Smart Structures and Materials. SPIE Vol. 5391, ed. S.C. Liu. San Diego, CA (2004) 344-355
15. Mastroleon, L., Kiremidjian, A.S., Carryer, E., Law, K.H.: Design of a New Power-efficient Wireless Sensor System for Structural Health Monitoring. Proc. of SPIE 9th Annual Int. Symp. on NDE for Health Monitoring and Diagnostics. SPIE Vol. 5395, ed. S.R. Doctor, Y. Bar-Cohen, A.E. Aktan, H.F. Wu. San Diego, CA (2004) 51-60
16. Ou, J.P., Li, H., Yu, Y.: Development and Performance of Wireless Sensor Network for Structural Health Monitoring. Proc. of SPIE 11th Annual Inter. Symp. on Smart Structures and Materials. SPIE Vol. 5391, ed. S.C. Liu. San Diego, CA (2004) 765-773
17. Shinozuka, M., Feng, M.Q., Chou, P., Chen, Y., Park, C.: MEMS-based Wireless Real-time Health Monitoring of Bridges. Proc. of 3rd Inter. Conf. on Earthquake Engng. Nanjing, China (2004)
18. Spencer, B.F. Jr., Ruiz-Sandoval, M.E., Kurata, N.: Smart Sensing Technology: Opportunities and Challenges. *Struct. Control Health Monit.* 11 (2004) 349-368
19. Wang, Y., Lynch, J.P., Law, K.H.: Wireless Structural Sensors using Reliable Communication Protocols for Data Acquisition and Interrogation. Proc. of 23rd Inter. Modal Anal. Conf. (IMAC XXIII). Orlando, FL (2005)
20. Lynch, J.P., Loh, K.: A Summary Review of Wireless Sensors and Sensor Networks for Structural Health Monitoring. *Shock and Vibration Dig.*. 38 (2005) 91-128
21. Lynch, J. P., Sundararajan, A., Sohn, H., Park, G., Farrar, C., Law, K.: Embedding Actuation Functionalities in a Wireless Structural Health Monitoring System. Proc. of 1st Inter. Workshop on Adv. Smart Materials and Smart Struct. Technology. Honolulu, HI (2004)
22. Grisso, B. L., Martin, L.A., Inman, D.J.: A Wireless Active Sensing System for Impedance-Based Structural Health Monitoring. Proc. of 23rd Inter. Modal Anal. Conf. (IMAC XXIII). Orlando, FL (2005)
23. Liu, L., Yuan, F.G., Zhang, F.: Development of Wireless Smart Sensor for Structural Health Monitoring. Proc. of SPIE Smart Struct. and Mat.. SPIE Vol. 5765. San Diego, CA (2005) 176-186

24. Casciati, F., Rossi, R.: Fuzzy Chip Controllers and Wireless Links in Smart Structures. Proc. of AMAS/ECCOMAS/STC Workshop on Smart Mat. and Struct. (SMART'03). Warsaw, Poland (2003)
25. Seth, S., Lynch, J. P., Tilbury, D.: Feasibility of Real-Time Distributed Structural Control upon a Wireless Sensor Network. Proc. of 42nd Annual Allerton Conf. on Comm., Control and Computing. Allerton, IL (2004)
26. Wang, Y., Swartz, A., Lynch, J.P., Law, K.H., Lu, K.-C., Loh, C.-H.: Wireless Feedback Structural Control with Embedded Computing, Proc. of SPIE 11th Inter. Symp. on Nondestructive Evaluation for Health Monitoring and Diagnostics. San Diego, CA (2006)
27. Churchill, D.L., Hamel, M.J., Townsend, C.P., Arms, S.W.: Strain Energy Harvesting for Wireless Sensor Networks. Proc. of SPIE 10th Annual Int. Symp. on Smart Struct. and Mat. SPIE Vol. 5055, ed. by Varadan, V.K. and Kish, L.B. San Diego, CA (2003) 319-327
28. Roundy, S.J.: Energy Scavenging for Wireless Sensor Nodes with a Focus on Vibration to Electricity Conversion. Ph.D. Thesis, Mech. Engng.. Univ. of California, Berkeley (2003)
29. Sodano, H.A., Inman, D.J., Park, G.: A Review of Power Harvesting from Vibration using Piezoelectric Materials. Shock and Vibration Dig.. 36 (2004) 197-205
30. Lei, Y., Kiremidjian, A.S., Nair, K.K., Lynch, J.P., Law, K.H.: Time Synchronization Algorithms for Wireless Monitoring System. Proc. of SPIE 10th Annual Int. Symp. on Smart Struct. and Mat.. SPIE Vol. 5057, ed. S.C. Liu. San Diego, CA (2003) 308-317
31. Lynch, J.P., Wang, Y., Law, K.H., Yi, J.H., Lee, C.G., Yun, C.B.: Validation of Large-Scale Wireless Structural Monitoring System on the Geumdang Bridge. Proc. of 9th Int. Conf. on Struct. Safety and Reliability. Rome, Italy (2005)
32. Lu, K.-C., Wang, Y., Lynch, J.P., Loh, C.-H., Chen, Y.-J., Lin, P.-Y., Lee, Z.-K.: Ambient Vibration Study of the Gi-Lu Cable-Stay Bridge: Application of Wireless Sensing Units. Proc of SPIE 13th Annual Symp. on Smart Struct. and Mat.. San Diego, CA (2006)
33. Lynch, J.P., Wang, Y., Lu, K.-C., Hou, T.-C., Loh, C.-H.: Post-seismic Damage Assessment of Steel Structures Instrumented with Self-interrogating Wireless Sensors. Proc. of 8th National Conf. on Earthquake Engng. San Francisco, CA (2006)
34. Sohn, H., Farrar, C.: Damage Diagnosis using Time-series Analysis of Vibrating Signals. J. of Smart Mat. and Struct.. 10 (2001) 446-451
35. Lee, C.-G., Lee, W.-T., Yun, C.-B., Choi, J.-S.: Summary Report - Development of Integrated System for Smart Evaluation of Load Carrying Capacity of Bridges. Korea Highway Corporation, Seoul, South Korea (2004)
36. Lin, P.-Y., Roschke, P.N., Loh, C.-H.: System Identification and Real Application of a Smart Magneto-Rheological Damper. Proc. of 2005 Int. Symp. on Intelligent Control, 13th Mediterranean Conf. on Control and Automation. Limassol, Cyprus (2005)
37. Franklin, G.F., Powell, J.D., Workman, M.: Digital Control of Dynamic Systems. Pearson Education (2003)
38. Domer, B. and Smith, I.F.C.: An Active Structure that Learns. J. Comput. in Civil Engng., 19 (2005) 16-24
39. Fest, E., Shea, K. and Smith, I.F.C.: Active Tensegrity Structure. J. Struct. Engng. 130 (2004) 1454-1465
40. Lynch, J.P., Law, K.H.: Decentralized Control Techniques for Large Scale Civil Structural Systems. Proc. of the 20th Int. Modal Analysis Conference (IMAC XX), Los Angeles, CA (2002)
41. Lynch, J.P., Law, K.H.: Decentralized Energy Market-Based Structural Control. Struct. Engng. and Mech., 17 (2004) 557-572
42. Wang, Y., Swartz, R.A., Lynch, J.P., Law, K.H., Lu, K.-C., and Loh, C.-H.: Decentralized Civil Structural Control using a Real-time Wireless Sensing and Control System. Proc. of the 4th World Conf. on Struct. Control and Monitoring, San Diego, CA (2006)